

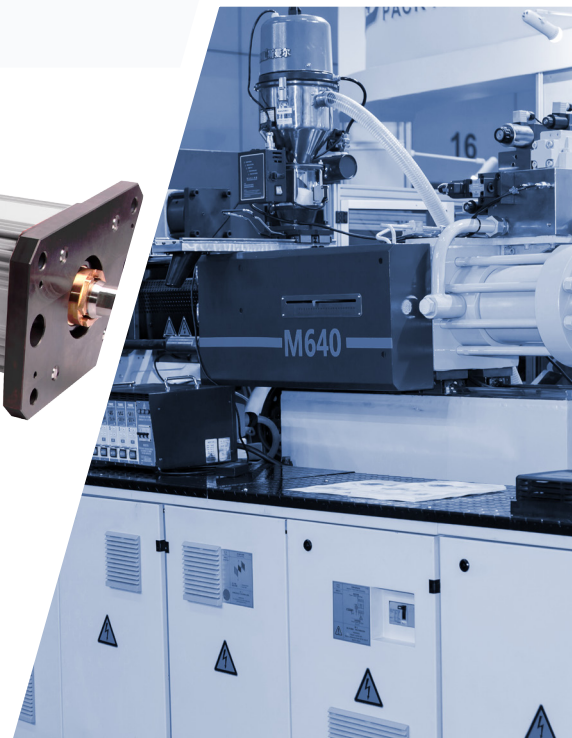

DIAKONT

ENGINEERED
TO **MOVE**

DA Series Electric Roller Screw Actuators with Integrated Motors

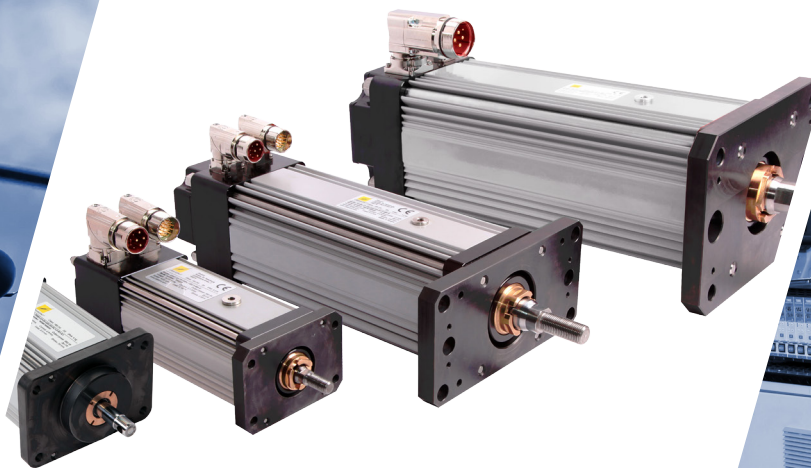

MACCON

MOTION UNDER CONTROL

**Vertrieb in Deutschland durch
MACCON GmbH
www.maccon.de**

ENGINEERED TO MOVE



DA Series Electromechanical Actuators (EMA)

The DA Series electromechanical actuators (EMAs) are equipped with an integrated motor and roller screw to provide superior performance in a compact space envelope. DA Series actuators are also outfitted with patented lubrication ports that support the actuator's only re-lubrication maintenance requirements without having to disassemble the unit or remove it from the customer's machinery.

Diakont is a full-cycle engineering, manufacturing, and service company that supplies motion control solutions that enhance the outstanding lifetime, safety, economy and efficiency of many industries. The DA Series actuators leverage Diakont's proven actuator designs to provide industry leading reliability, force and precision.



Key Features

- Continuous force: up to 22,300 N (5,013 lbf)
- Nominal backlash: 0.1 mm (0.004 in)
- Lead accuracy: 0.025 mm/300mm (0.001 in/ft)
- Speed: up to 833 mm/s (32.8 in/sec)
- Integrated motor and roller screw
- Lubrication ports for easy maintenance without disassembly

State-of-the-Art Solutions

Diakont EMA's incorporate state-of-the-art component designs to provide industry leading precision, power and reliability.







Advanced Roller Screw designs provide a high-performance method for converting rotary torque to linear motion. With more cumulative contact surface and a lack of backlash, Diakont's advanced roller screws significantly exceed competitor solutions in terms of higher reliability, lifetime, load capacity, tolerance to shock loads, absence of vibrations and efficiency output.



Permanent Magnet Synchronous Motor designs are the ultimate solution for providing high accuracy in high dynamic/force motion, while delivering exceptional reliability. The motor's rotating motion is transferred to the output shaft by a "direct drive" system.



Diakont DA Series Actuator Applications

	Weld Guns
	Injection molding Including hot runner systems
	Presses Servo press designs
	Automation Machine designs for filling, pressing and cutting
	Steam Turbine Power generation actuators and controls for fossil and nuclear plants
	Machine Tools Vertical axis and precision machining

Diakont's DA Series actuators are ideal for robotics, weld guns, machine tool positioning, semiconductor manufacturing, packaging machines, injection molding, and more.

DA67/99/140 EMA Specifications

Model	Peak force	Max. velocity	Cont. force rating (stall)	Min. stroke	Thread lead	Dynamic load rating
DA140-22	60,000 N <i>(13,489 lbf)</i>	100 mm/sec <i>(3.9 in/sec)</i>	36,300 N <i>(8,161 lbf)</i>	220 mm <i>(8.7 in)</i>	2.5 mm <i>(0.1 in)</i>	114,000 N <i>(25,628 lbf)</i>
DA140-25	44,600 N <i>(10,027 lbf)</i>	200 mm/sec <i>(7.9 in/sec)</i>	22,300 N <i>(5,013 lbf)</i>	220 mm <i>(8.7 in)</i>	5 mm <i>(0.2 in)</i>	98,000 N <i>(22,031 lbf)</i>
DA99-W22	24,000 N <i>(5,395 lbf)</i>	150 mm/sec <i>(5.9 in/sec)</i>	17,300 N <i>(3,889 lbf)</i>	150 mm <i>(5.9 in)</i>	2.5 mm <i>(0.1 in)</i>	53,600 N <i>(12,050 lbf)</i>
DA99-W35	24,000 N <i>(5,395 lbf)</i>	300 mm/sec <i>(11.8 in/sec)</i>	13,000 N <i>(2,923 lbf)</i>	200 mm <i>(7.9 in)</i>	5 mm <i>(0.2 in)</i>	56,000 N <i>(12,589 lbf)</i>
DA99-W25	22,000 N <i>(4,946 lbf)</i>	300 mm/sec <i>(11.8 in/sec)</i>	9,700 N <i>(2,181 lbf)</i>	150 mm <i>(5.9 in)</i>	5 mm <i>(0.2 in)</i>	56,000 N <i>(12,589 lbf)</i>
DA99-W312	15,000 N <i>(3,372 lbf)</i>	750 mm/sec <i>(29.5 in/sec)</i>	6,050 N <i>(1,360 lbf)</i>	200 mm <i>(7.9 in)</i>	12.5 mm <i>(0.5 in)</i>	48,200 N <i>(10,836 lbf)</i>
DA78-22	13,000 N <i>(2,923 lbf)</i>	150 mm/sec <i>(5.9 in/sec)</i>	6,250 N <i>(1,405 lbf)</i>	75 mm <i>(3 in)</i>	2.5 mm <i>(0.1 in)</i>	32,000 N <i>(7,194 lbf)</i>
DA78-35	13,000 N <i>(2,923 lbf)</i>	300 mm/sec <i>(11.8 in/sec)</i>	4,600 N <i>(1,034 lbf)</i>	150 mm <i>(5.9 in)</i>	5 mm <i>(0.2 in)</i>	33,500 N <i>(7,531 lbf)</i>
DA78-25	9,000 N <i>(2,023 lbf)</i>	300 mm/sec <i>(11.8 in/sec)</i>	3,500 N <i>(787 lbf)</i>	75 mm <i>(3 in)</i>	5 mm <i>(0.2 in)</i>	20,700 N <i>(4,654 lbf)</i>
DA99-W212	8,800 N <i>(1,978 lbf)</i>	750 mm/sec <i>(29.5 in/sec)</i>	4,300 N <i>(967 lbf)</i>	150 mm <i>(5.9 in)</i>	12.5 mm <i>(0.5 in)</i>	48,200 N <i>(10,836 lbf)</i>
DA67-22	5,560 N <i>(1,250 lbf)</i>	208 mm/sec <i>(8.2 in/sec)</i>	2,670 N <i>(600 lbf)</i>	75 mm <i>(3 in)</i>	2.5 mm <i>(0.1 in)</i>	25,270 N <i>(5,681 lbf)</i>
DA67-210	1,446 N <i>(325 lbf)</i>	833 mm/sec <i>(32.8 in/sec)</i>	723 N <i>(163 lbf)</i>	75 mm <i>(3 in)</i>	10 mm <i>(0.4 in)</i>	7,500 N <i>(1,686 lbf)</i>

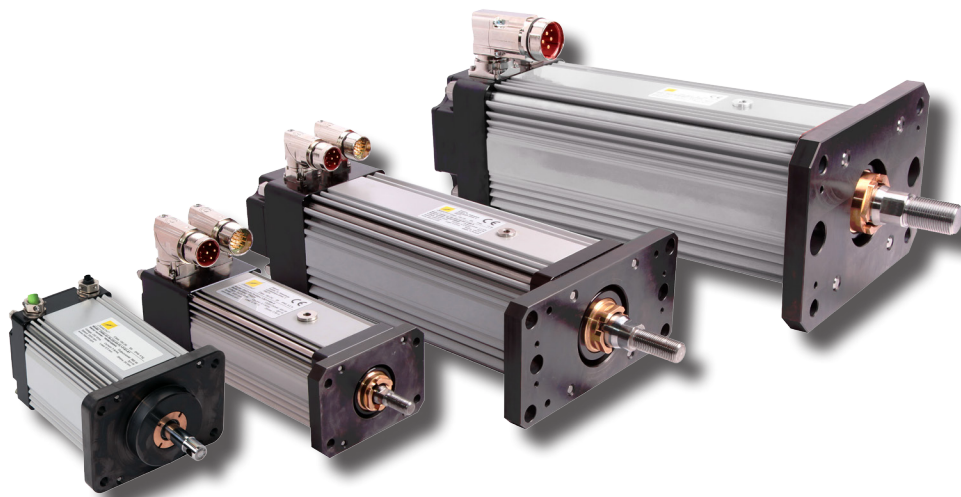



DA Series EMA Advantages

Best in Class Lifetime Reliability

Diakont DA Series actuators provide superior service life as a result of using robust components such as roller screws (up to 10 times longer than ball-screw). With a greater number of contact points than ball-screw solutions, roller screws provide increased load capacity and rigidity. Diakont design and manufacturing technologies are specially optimized to increase Roller Screw lifetime, due to the optimized geometry of the roller-screws and hardening technology used in the manufacturing process. Diakont offers complete turnkey EMA solutions as well as individual components for your specified needs.

Compact Design

Diakont EMAs are equipped with inverted roller screws, which require much less space than equivalent ball-screw or hydraulic solutions. This compact design allows end users to easily replace hydraulic or pneumatic actuators with Diakont EMAs. The EMA is also compatible with most servo drives.

High Accuracy

Diakont DA Series actuators deliver lead accuracy of 0.025 mm/m (0.0003 in/ft) along with a nominal backlash of 0.1 mm (0.004 in) - zero backlash options available upon request. The integration of advanced roller screws, which provide significantly higher positioning accuracy over competitor solutions (due to the precisely machined threads), result in high overall accuracy.

Easy Maintenance

Relubrication is the only maintenance the EMA needs. Diakont EMAs are equipped with easily accessible patented lubrication ports to facilitate scheduled maintenance, without requiring disassembly, recalibration, or removal from the customer's machinery.

Easy Lubrication Ports

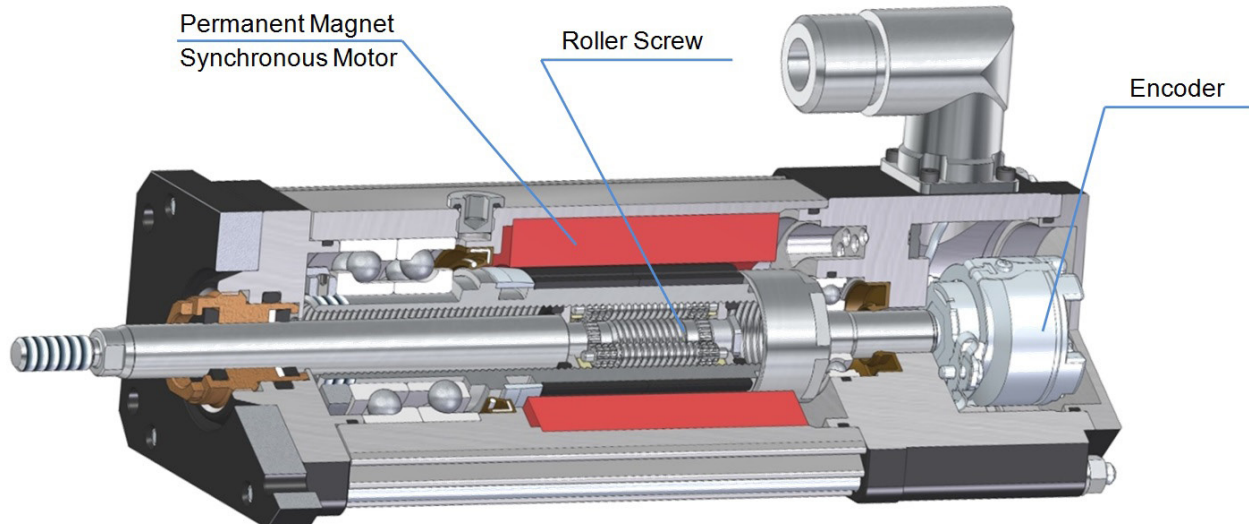
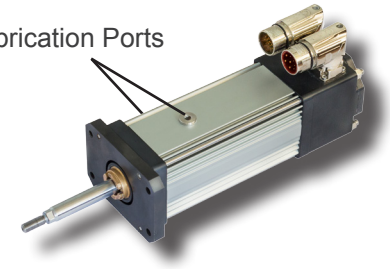



Electrical Specifications

DA67 Electrical Specifications

Standard	230 VAC	400 VAC	480 VAC
Rated motor torque	1.53 Nm (13.54 lbf-in)	1.53 Nm (13.54 lbf-in)	1.50 Nm (13.28 lbf-in)
Speed @ Bus Voltage	5000 RPM	5000 RPM	5000 RPM
Power	0.80 kW	0.80 kW	0.78 kW
Insulated thermal endurance class	180 (H)	180 (H)	180 (H)
Thermal switch temperature	130°C (266°F)	130°C (266°F)	130°C (266°F)
Continuous current, A	3.1	1.56	1.26
Peak current, A	6.2	3.2	2.56

DA99 Electrical Specifications

Standard	230 VAC	400 VAC
Rated motor torque	7.9 Nm (69.9 lbf-in)	7.9 Nm (69.9 lbf-in)
Speed @ Bus Voltage	3000 RPM	3000 RPM
Power	2.9 kW	2.9 kW
Insulated thermal endurance class	180 (H)	180 (H)
Thermal switch temperature	130°C (266°F)	130°C (266°F)
Continuous current, A	10.8	5.3
Peak current, A	21.6	10.6

DA140 Electrical Specifications

Standard	230 VAC	400 VAC
Rated motor torque	20.1 Nm (177.9 lbf-in)	20.1 Nm (177.9 lbf-in)
Speed @ Bus Voltage	2400 RPM	2400 RPM
Power	5.6 kW	5.6 kW
Insulated thermal endurance class	180 (H)	180 (H)
Thermal switch temperature	130°C (266°F)	130°C (266°F)
Continuous current, A	20.0	11.6
Peak current, A	40.0	23.2



Performance Diagrams

Diakont DA67, DA99, and DA140 Series EMAs utilize permanent magnet synchronous motors to provide rated force throughout the entire range of velocities, even at maximum rod speed.

DA67-22

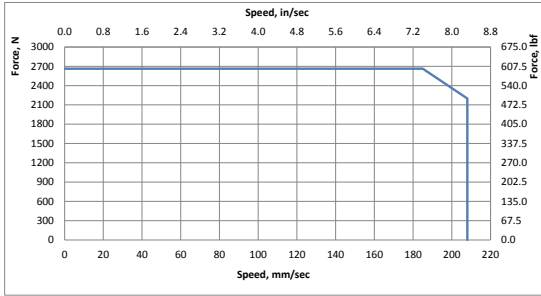

DA67-210

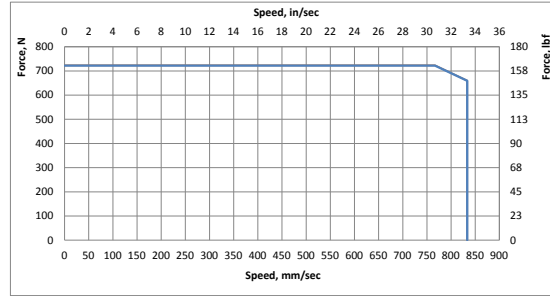

DA140-22

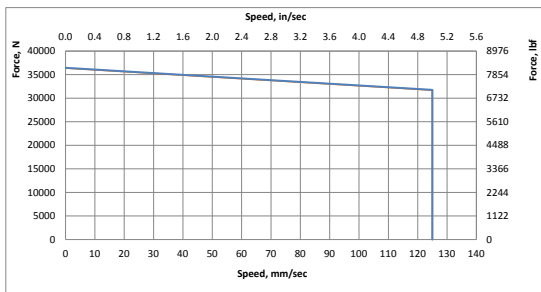

DA140-25

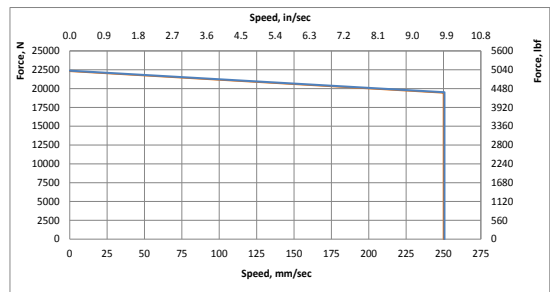

DA140-212

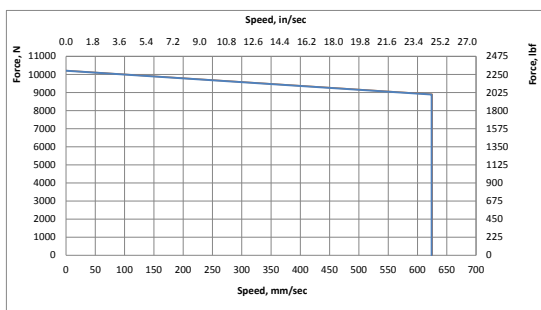



Operating Life

DA67 Operating Life

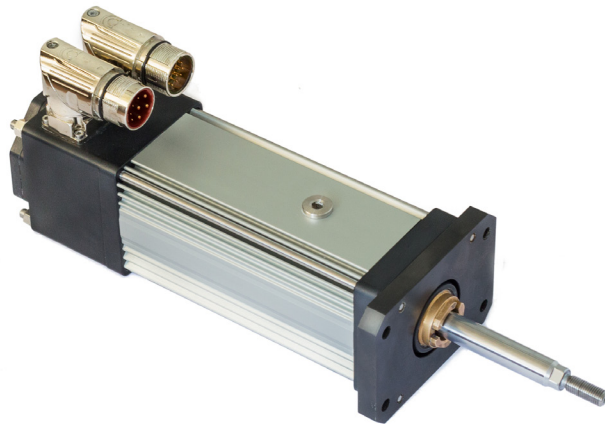
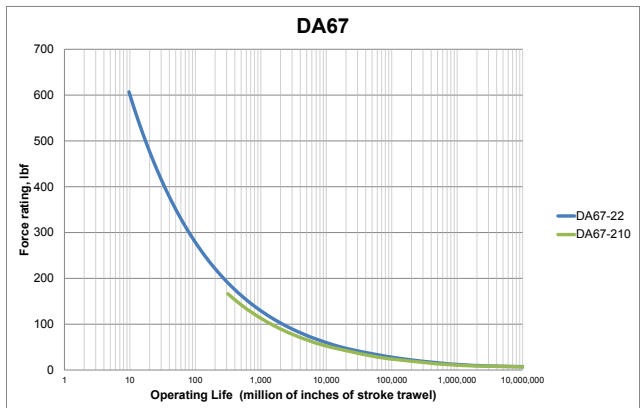

DA99 Operating Life

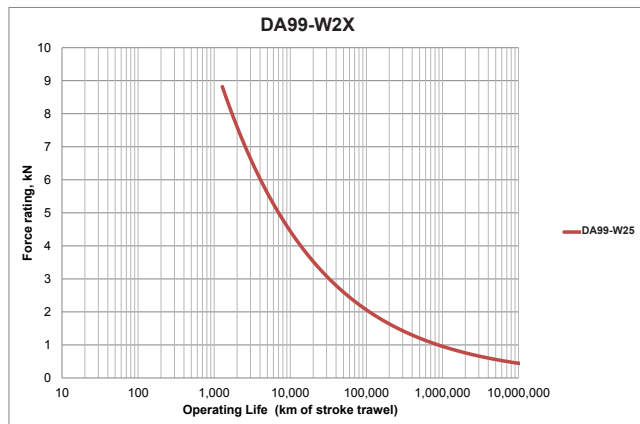

DA140 Operating Life

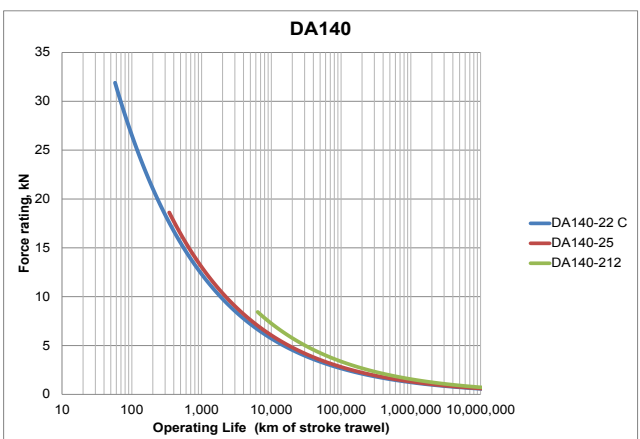



Environmental Performance

Diakont DA Series EMAs are constructed from ruggedized components designed to operate reliably in harsh environmental conditions. Aside from operating in temperature extremes, Diakont EMAs are also built to withstand the shock and vibration associated with the most demanding applications. Diakont DA Series can be offered with higher protection levels (IP66) or higher temperature ratings (-55°C to +150°C ~ -67°F to +302°F).

Environment temperature	-15° to +40°C (+5° to +104°F)
Relative degree of humidity	90% at +25°C (+77°F)
Protection level	IP65
Vibration	2g, 1-10 Hz
Shockproof	3g, 11 ms
Explosion proof	Optional

Shock and Vibration Tolerance

Standard Diakont EMAs have high shock and vibration-proof characteristics, achieved through the use of:

- Backlash-free roller screws (with pre-load)
- Vibration-proof, shockproof sensors
- Solid stator without any moving parts

Temperature Tolerance

The EMA can be made in temperature-proof by using a heat-resistant resolver, motor magnets and a special composite designed to operate over a wide temperature range.

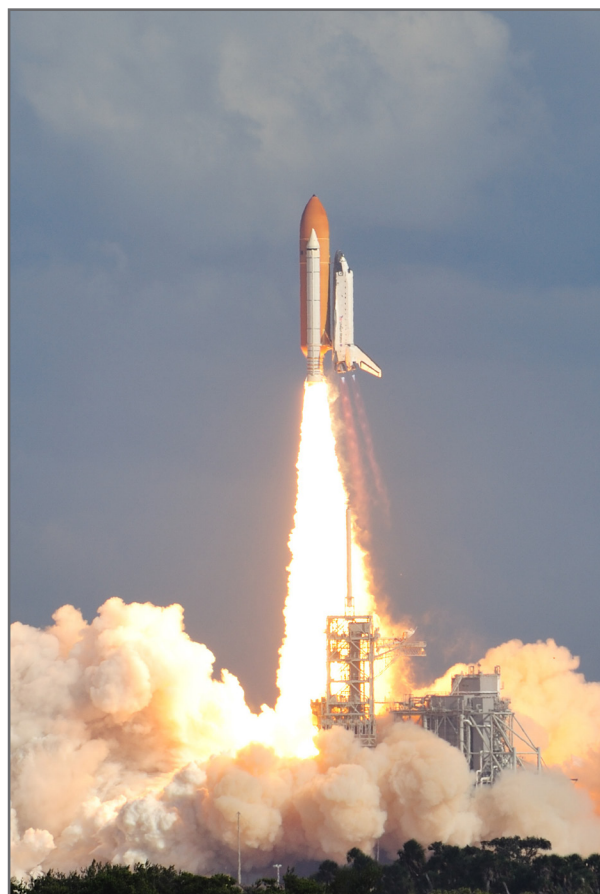

DA67 - Specifications

DA67 Dimensions

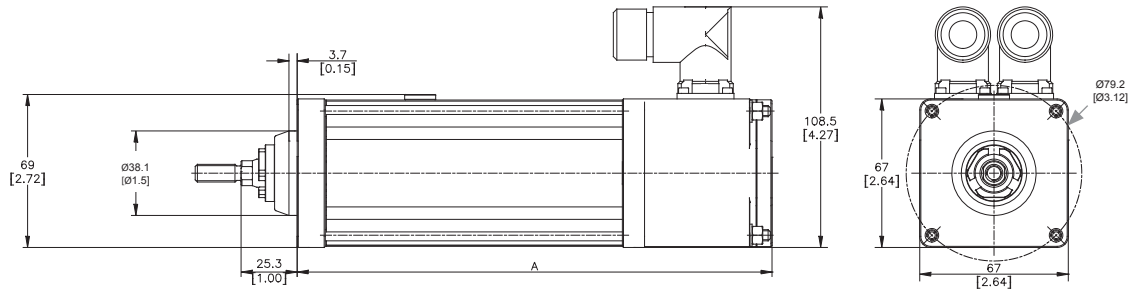

See the physical specifications table below for length of "A"

DA67 Physical Specifications

The following weight specifications are based on EMAs without front flange mounting.

Stroke	75 mm	150 mm	250 mm	300 mm
Length of "A"	214.2 mm (8.4")	289.2 mm (11.4")	389.2 mm (15.3")	439.2 mm (17.3")
Weight	3.3 kg (7.3 lb)	4.1 kg (9.0 lb)	5.0 kg (11.2 lb)	5.5 kg (11.9 lb)

DA67 Functional Specifications

DA67 Specifications	Standard	Optional
Stroke, mm (in)	75 (2.9), 150 (5.9), 250 (9.8), 300 (11.8)	Based on customer requirements
Voltage	230-480 VAC	
Power	0.5-0.8 kW	
Primary feedback	Incremental encoder or resolver	Absolute encoder (Hiperface)
Lead accuracy, mm/300mm (in/ft)	0.025 (0.001)	
Nominal backlash, mm (in)	0.1 (0.004)	Zero-backlash

DA99 - Specifications

DA99 Dimensions

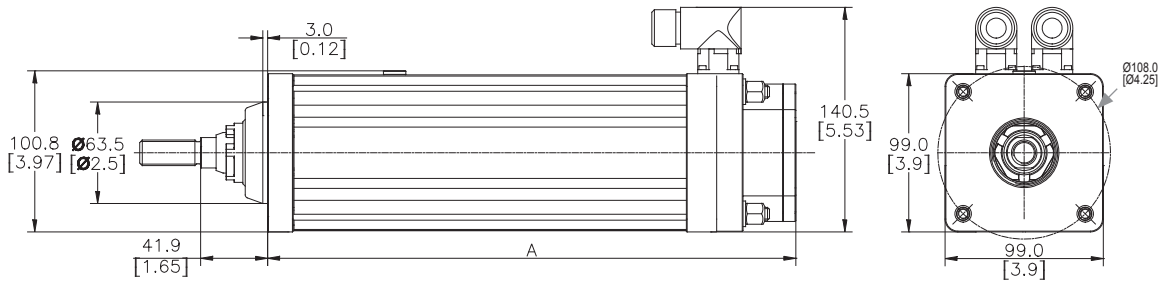

See the physical specifications table below for length of "A"

DA99 Physical Specifications

The following weight specifications are based on EMAs without front flange mounting.

Model length	Stroke		
	150 mm	200 mm	300 mm
DA99	320.0 mm (12.6")	370.0 mm (14.6")	470.0 mm (18.5")

Model weight (excluding front flange)	Stroke		
	150 mm	200 mm	300 mm
DA99-25*	10.6 kg (23.4 lb)	11.7 kg (25.8 lb)	13.8 kg (30.4 lb)

*The size and weight parameters listed for these variants do not include relubrication ports

DA99 Functional Specifications

DA99 Specifications	Standard	Optional
Stroke, mm (in)	150 (5.9), 200 (7.9), 300 (11.8)	Up to 450 (17.7)
Voltage	230-400 VAC	Based on customer requirements
Power	1.7-2.9 kW	
Primary feedback	Incremental encoder or resolver	Absolute encoder (Hiperface)
Lead accuracy, in/ft (mm/300mm)	0.001 (0.025)	
Nominal backlash, mm (in)	0.1 (0.004)	Zero-backlash

DA67 Mounting Options

Front Flange Mounting

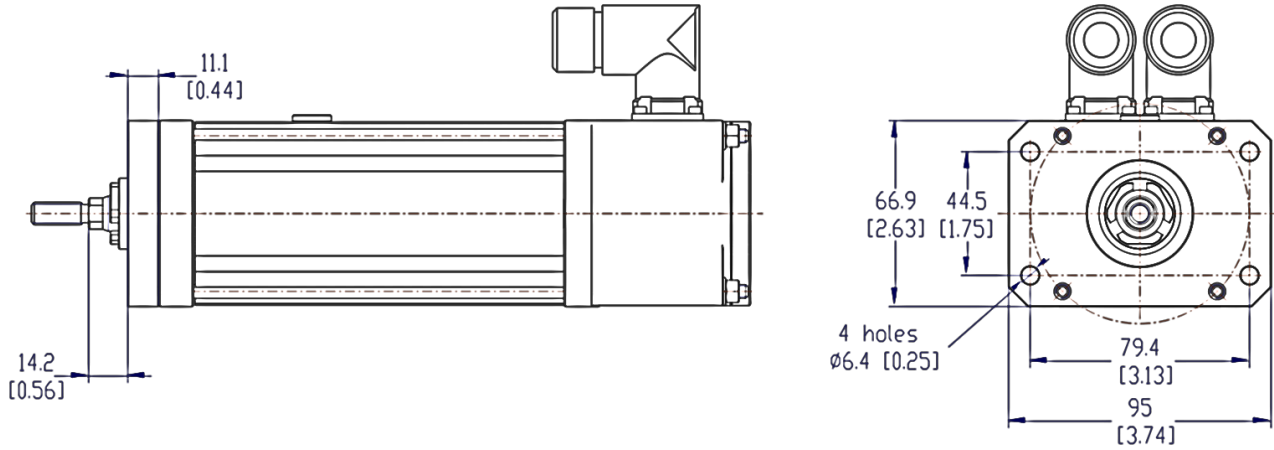

Rear Clevis Mount

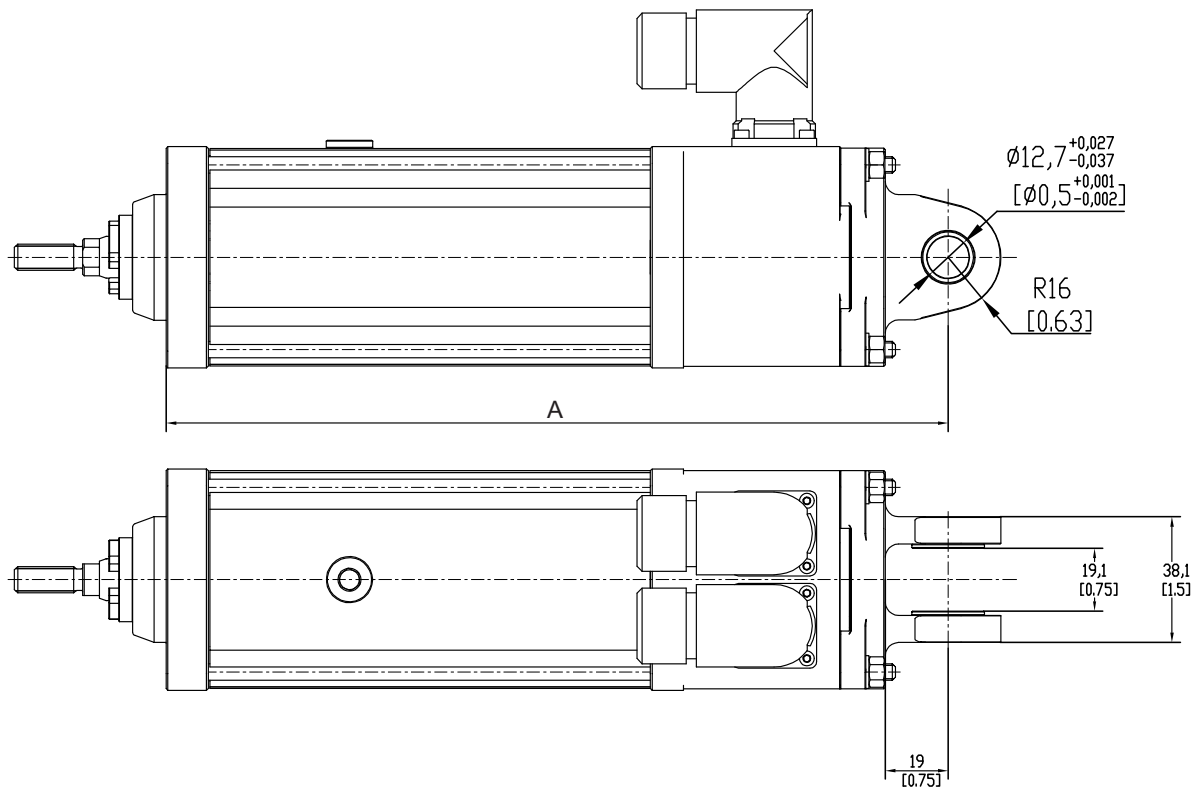

Length	Stroke, mm (in)			
	75	150	250	300
A	237.0 [9.33]	312.0 [12.28]	412.0 [16.22]	462.0 [18.19]

DA67 Mounting Options

Extended Tie-Rod Mounting

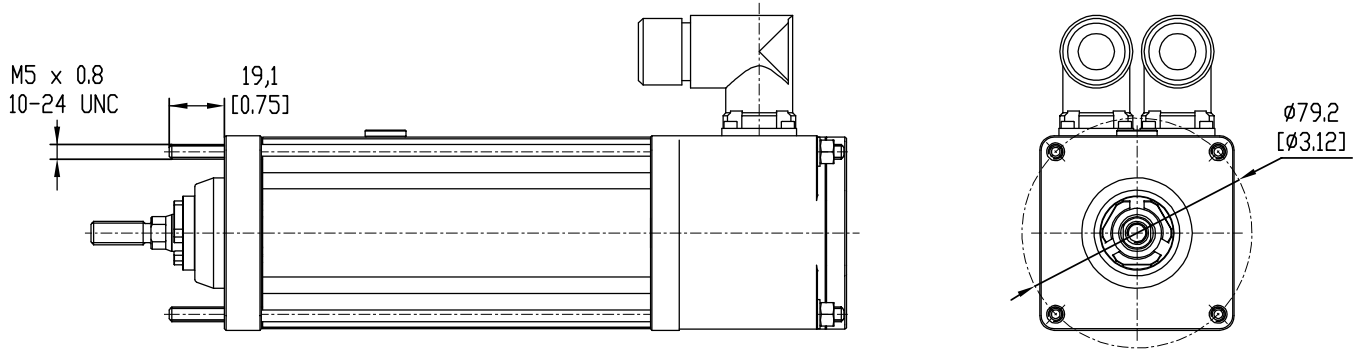

Trunnion Mount

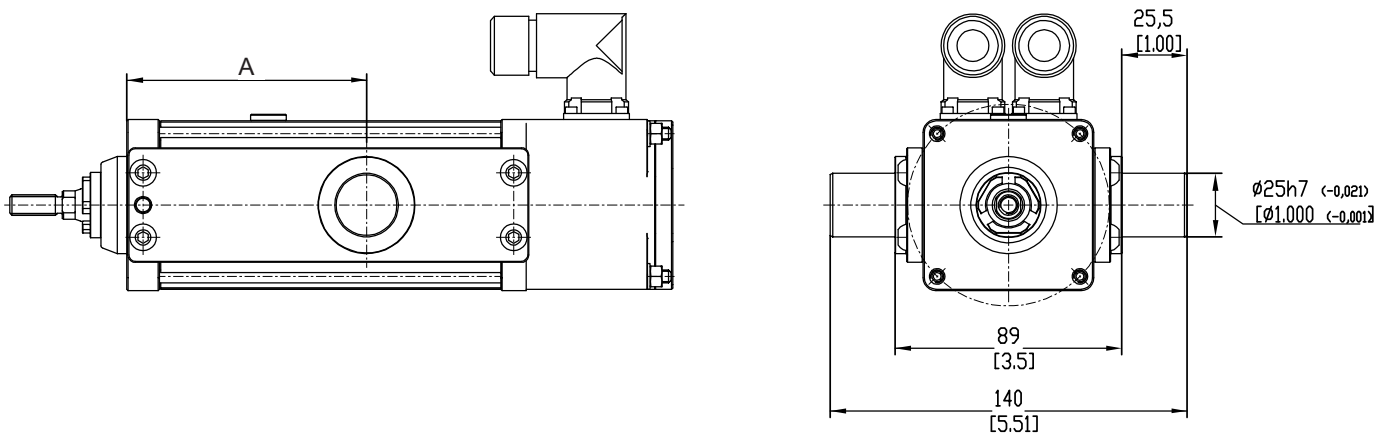

Length	Stroke, mm (in)			
	75	150	250	300
A	94.0 [3.70]	133.0 [5.24]	185.0 [7.28]	210.0 [8.27]

DA99 Mounting Options

Front Flange Mounting

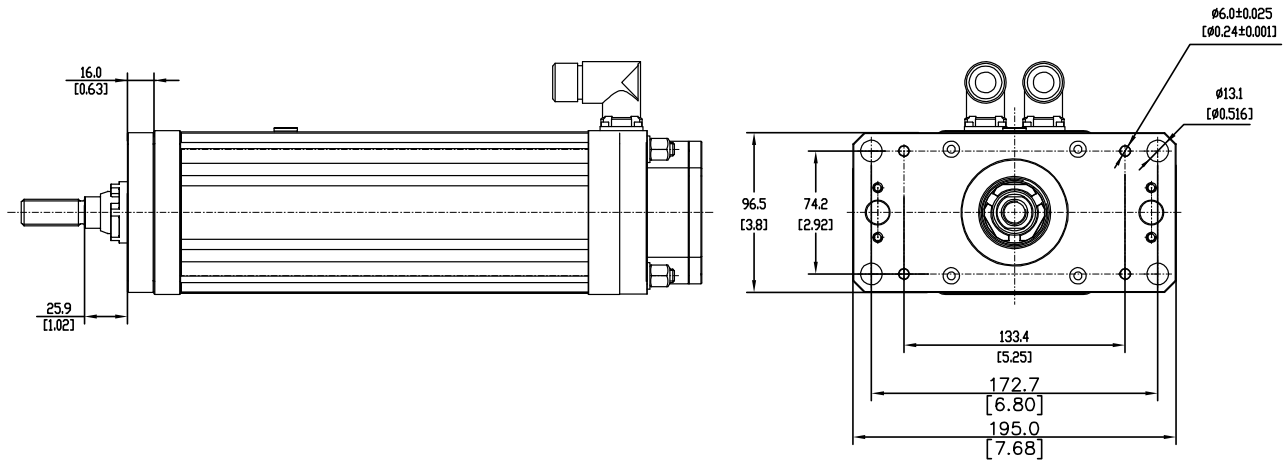

Rear Clevis Mounting

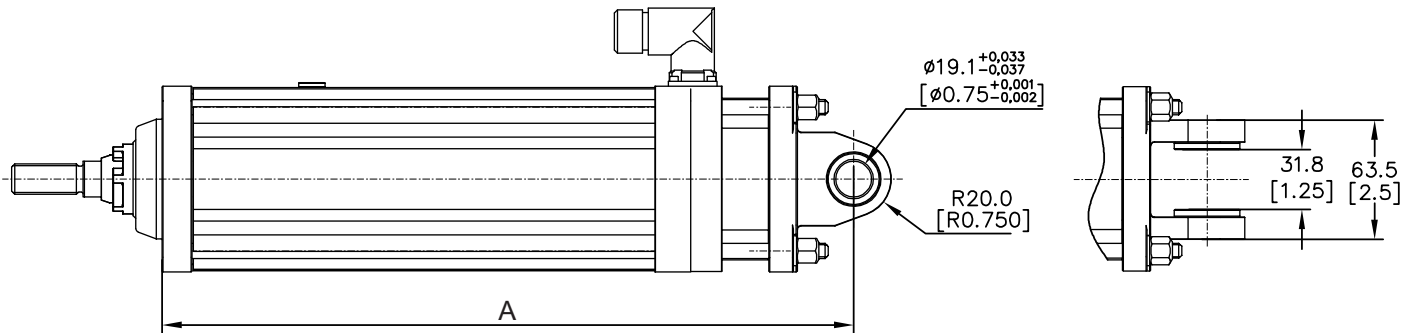

Length	Stroke, mm (in)		
	150	200	300
A	367 [14.5]	417 [16.4]	517 [20.4]

DA99 Mounting Options

Extended Tie-Rod Mounting

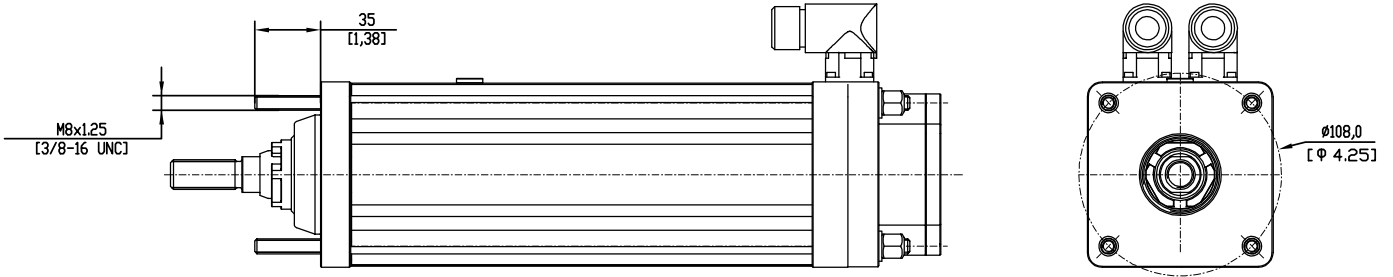

Trunnion Mounting

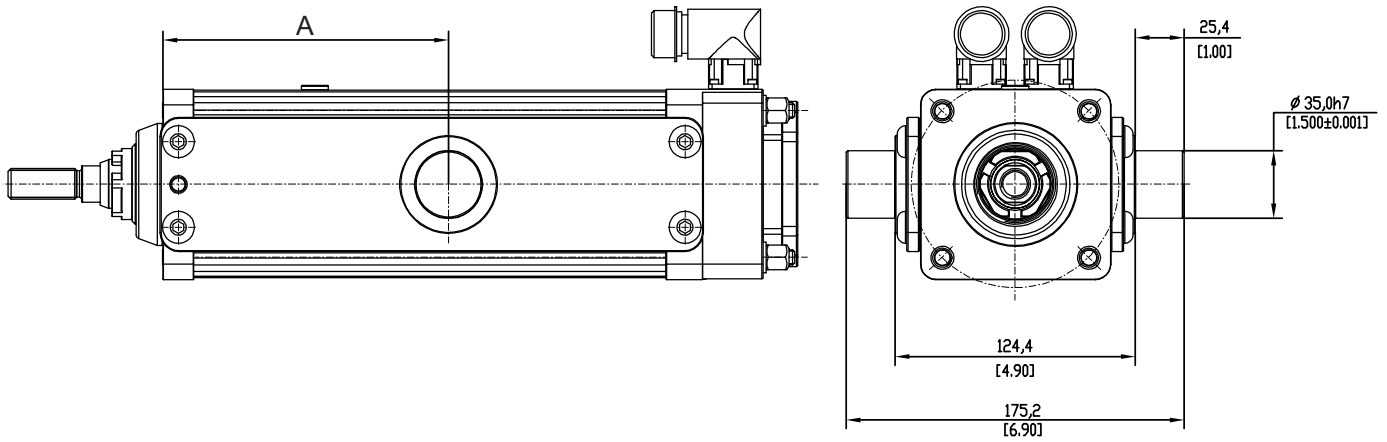

Length	Stroke, mm (in)		
	150	200	300
A	148 [5.8]	198 [7.8]	298 [11.7]

DA140 Mounting

DA140 diagrams and mounting options provided upon request.

Rod Ends

Type E1

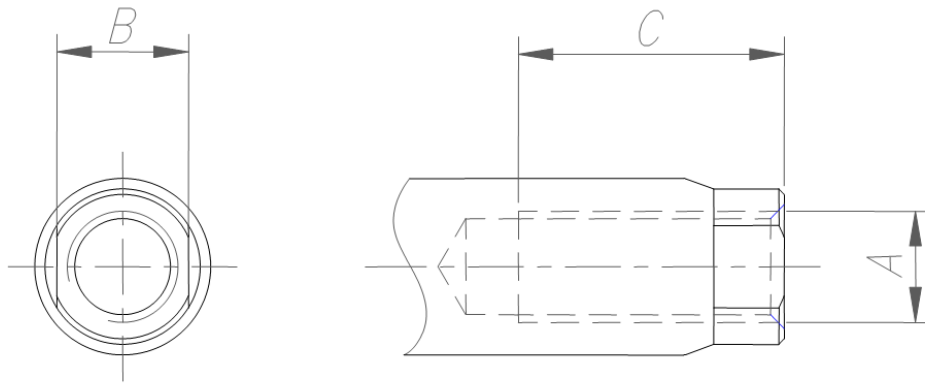

Type E2

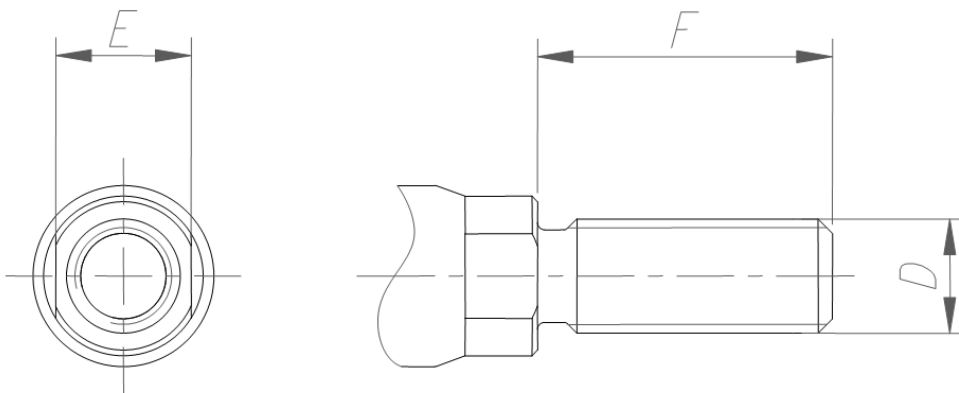

EMA model	Sizes					
	A, mm	B, mm	C, mm	D, mm	E, mm	F, mm
DA67	M8x1	9.5 (0.37")	19.1 (0.75")	M8x1	9.5 (0.37")	24 (0.94")
DA99	M16x1.5	19.1 (0.75")	25.4 (1.00")	M16x1.5	19.1 (0.75")	38.1 (1.50")



Design and Development

Diakont offers a broad range of standard actuators to suit most requirements. We also realize that often special application parameters dictate special actuator configurations and modifications. Diakont actuators are designed with this in mind, as many of our products can be readily customized to suit specific requirements. Additionally, Diakont development teams, comprised of mechanical, electrical and application design engineers, handle every aspect of the development process from design to prototype to test and manufacture.

Diakont utilizes cutting edge technology for the design and development of electromechanical actuators and subassemblies. Diakont also created a specialized computer-aided design software for performing calculations and modeling planetary-lantern gears, roller screws, and synchronous motors. This advanced program helps development teams design actuators to exact specifications of power, accuracy, and space constraints.

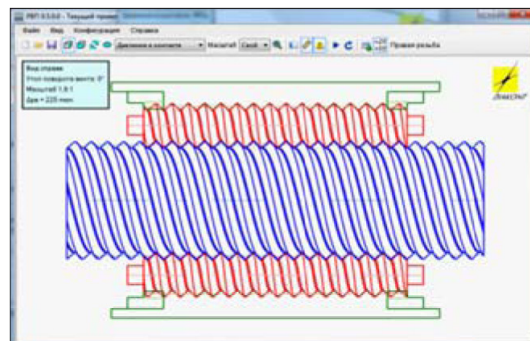
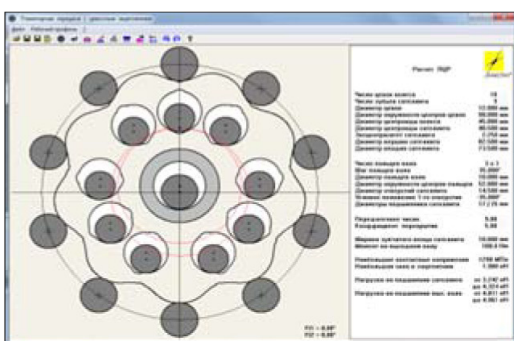



DA Series EMA Ordering Guide

Model: DA67-22-300-230-S1-SC-F-ME-ABCL2PRST1

Sizes:

67	67 mm (2.6 in)
78	78 mm (3.1 in)
99	99 mm (3.9 in)
140	140 mm (5.5 in)

Motor type:

2	2 Stack
---	---------

Thread lead/transmission ratio:

2	2.5 mm/rev (0.1 in/rev)
5	5 mm/rev (0.2 in/rev)
10	10 mm/rev (0.4 in/rev)
12	12.5mm/rev (0.5 in/rev) DA67 only

Rod stroke:

75	75 mm (2.95 in) DA67 only
150	150 mm (5.91 in)
200	200 mm (7.87 in)
220	220 mm (8.7 in) DA99 only
280	280 mm (11.0 in)
300	300 mm (11.8 in)
350	350 mm (13.8 in)

Supply Voltage:

230	230 V
400	400 V
480	480 V

Feedback type*:

S1	Sick Stegmann SKM36 absolute encoder
S2	Heidenhain EQN 1125 absolute encoder
S3	Sick Stegmann SRM50 absolute encoder
S4	Heidenhain EQN 1325 absolute encoder
H1	Sick Stegmann CKS36 incremental encoder
H2	Sick Stegmann CFS50 incremental encoder
L1	LTN RE-15-1-A14-06 resolver
F1	Fanuc absolute encoder

Options:

X	No options (select if no options req'd)
A	Anti-rotation device
B	Brake
C	Oil cooling
P	Preloaded roller screw
R	Rear manual drive (available with L1 sensor)
S	Side manual drive
T1	Protective corrugated tube
T2	High-temperature protective corrugated tube
U	Load cell sensor
V	Vibration proof

Rod end:

MA	External inch thread
ME	External metric thread
FA	Internal inch thread
FE	Internal metric thread
BJ	Spherical ball joint (spherical eye)
FJ	Fork joint

Mounting options:

F	Front flange
C	Clevis (not available with F1 sensor)
E	Extended tie-rods
T	Trunnion

(list extends each time after EMA with a new mounting is developed)

Connectors:

SC	Standard M23
FL	Flying leads

*Not all ordering options are available for each model. Contact a local Diakont representative for more information



ENGINEERED TO MOVE



MOTION UNDER CONTROL

**Vertrieb in Deutschland durch
MACCON GmbH
www.maccon.de**

North America

3853 Calle Fortunada,
San Diego, CA 92123 USA
+1-858-551-5551
sales@diakont.us.com

Russia

2 Uchitelskaja St.,
St. Petersburg 195274 Russia
+7-812-324-6637
sales@diakont.com

Italy

Via Achille Grandi nc.10/12
52100 Arezzo, Italy
+39-0575-250332
sales.it@diakont.com

www.Diakont.com

