

GPM12LR

The Printed Motor Works GPM12LR is a totally enclosed dc motor in an ultra slim pancake profile. This pancake motor can provide a cost effective servo capability either direct drive or combined with a timing pulley/gearbox.

Features & Benefits

- Ultra slim profile
- Minimum torque ripple
- Very low inertia
- High peak torques
- Zero cogging
- Ultra slow/creep capability
- Low inductance
- EMC compatible

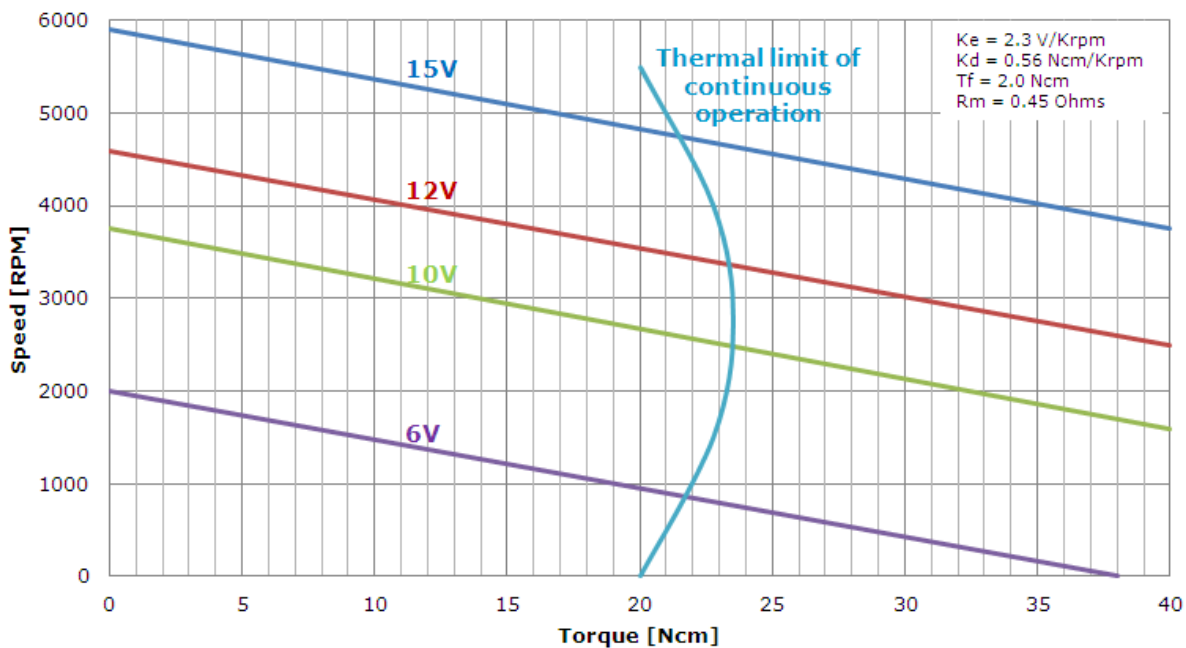
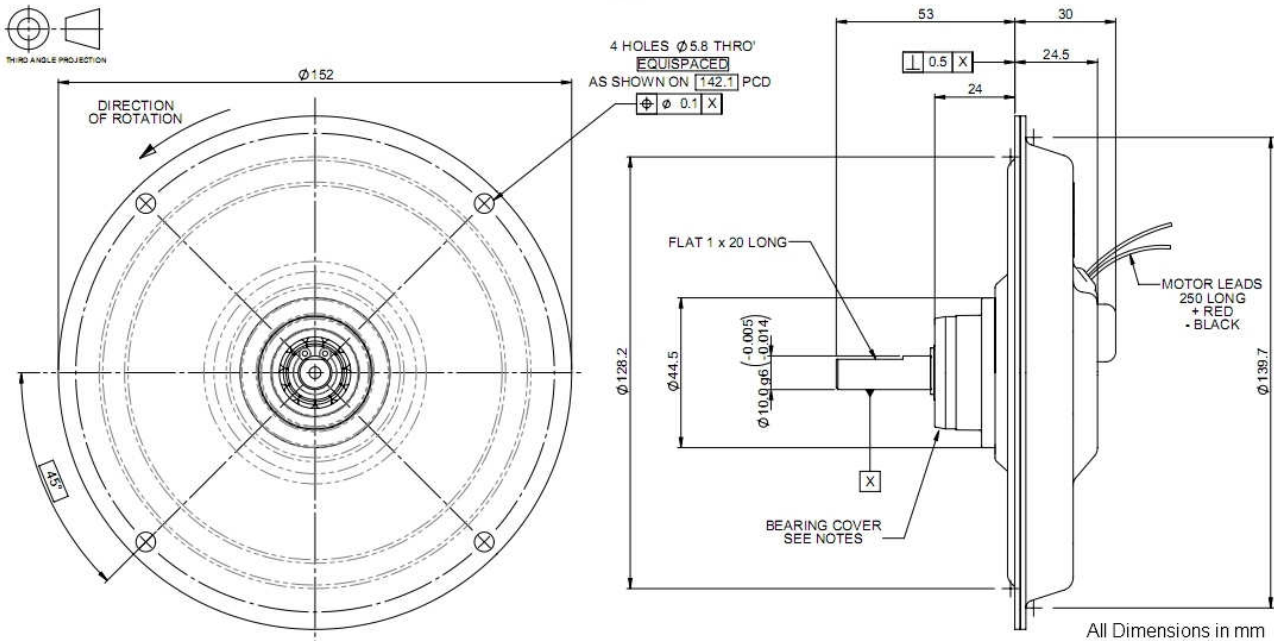
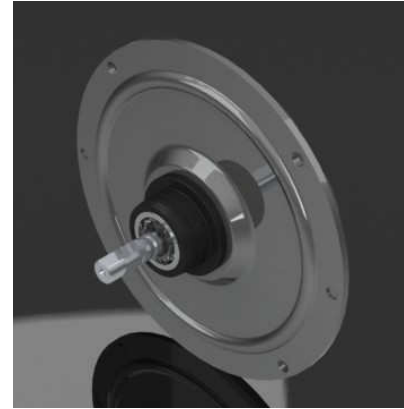

NOTE: The above voltages are examples, not a predefined maximum or minimum. Due to ongoing product improvements data is subject to change without notice.

Applications: Servo mechanisms, motion control, industrial robots, CNC machining, printing machinery, logistics solutions, medical mobility, medical scanners, flight simulators, marine autopilots and high ambient temperature ventilation.

Markets: Industrial automation, automotive, medical, life sciences, aerospace, printing, logistics, instrumentation, test and measurement, oil & gas and offshore marine.

Design Modifications

- Encoders
- Timing pulleys
- Long leads
- Tri-rated cable
- Open/kit option
- Customised shafts
- EMC suppression
- Connectors
- Rated for operation in 150°C ambient
- Mounting customisation

Performance Specifications	Symbol	Units	GPM12LR
Peak Torque	Tp	N/cm (oz/in)	278 (393)
Rated Speed	N	RPM	3050
Rated Continuous Torque @ 25°C	T ₂₅	N/cm (oz/in)	23.5 (33.28)
Rated Power Output	P	Watts	64
Maximum Recommended Speed	N _{max}	RPM	6000
Continuous Stall Torque	Ts	N/cm (oz/in)	22 (31)
Cogging Torque	Tc	N/cm (oz/in)	0 (0)
Electrical Specifications			
Rated Terminal Voltage	E	Volts	12
Rated Continuous Current	I	Amps	10.8
Peak Current	Ip	Amps	136
Continuous Stall Current	Is	Amps	6
Winding Specifications			
Terminal Resistance ± 10%	Rm	Ohms	0.45
Armature Resistance ± 10%	Ra	Ohms	0.21
Back EMF Constant ± 5%	Ke	V/kRPM	2.3
Torque Constant ± 5%	Kt	N/cm/Amp (oz/in/Amp)	2.34 (3.32)
Viscous Damping Constant	Kd	N/cm/KRPM (oz/in/KRPM)	0.56 (0.6)
Armature Inductance	L	µH	<0.03
Temperature Coefficient of KE	C	%/°C Rise	-0.19
Number of Commutation Bars	Z		141
Mechanical Specifications			
Moment of Inertia	Jm	kg/cm ² (oz/in/sec ²)	1.624 (0.023)
Average Friction Torque	Tf	N/cm (oz/in)	2 (3.5)
Weight	W	kg (lbs)	1 (2.2)
Diameter	D	mm (In)	152 (5.984)
Length	LG	mm (In)	30 (1.181)
Permitted Radial Load		Kg (lbs)	3.5 (7.72)
Permitted Axial Load		Kg (lbs)	3.5 (7.72)
Figure of Merit			
Mechanical Time Constant	Tm	ms	50.7
Electrical Time Constant	Te	ms	<0.12
Thermal Specifications			
Thermal Resistance at Rated Speed	RAAR	°C/Watt	1.7
Thermal Resistance at Stall	RAAS	°C/Watt	2.03