

# GPG12 Series

Peak Torque **17 Nm to 1134 Nm**  
 Cont. Torque **49 to 255 Ncm**  
 Ratios **10:1 to 206:1**  
 Speed **<0.1 to 500 rpm**

The Printed Motor Works GPG12 series offers a wide range of gear reduction ratios for the GP12 motors. Offering high torque in a compact axial package, each unit has foot mounting capability and uses a combination of bevel and planetary gears to reduce the speed and efficiently increase the torque of the 12cm pancake motor. Each unit comes with gearbox and motor fully assembled.

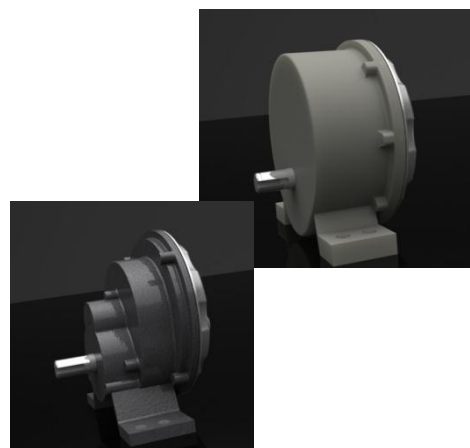

GPG12 Series

Motor	Gear Ratio (value : 1)	206	120	80	60	40	25	12	10
GPGM12	Continuous (Nm)	71	41	28	21	14	9	4	3
	Current (Amp)	7.6	7.6	7.6	7.6	7.6	7.6	7.6	7.6
	Speed (RPM) @ 24v	15	25	38	50	75	120	250	300
	Speed (RPM) @ 12v	7	13	19	25	38	60	125	150
GPGN12	Continuous (Nm)	133	77	52	39	26	16	8	6
	Current (Amp)	7.3	7.3	7.3	7.3	7.3	7.3	7.3	7.3
	Speed (RPM) @ 36v	15	25	38	50	75	120	250	300
	Speed (RPM) @ 24v	10	17	25	33	50	80	167	200
GPGM12LR	Continuous (Nm)	35	21	14	10	7	4	2	2
	Current (Amp)	10.8	10.8	10.8	10.8	10.8	10.8	10.8	10.8
	Speed (RPM) @ 24v	24	42	63	83	125	200	417	500
	Speed (RPM) @ 12v	12	21	31	42	63	100	208	250
GPGN12LR	Continuous (Nm)	87	51	34	25	17	11	5	4
	Current (Amp)	11.0	11.0	11.0	11.0	11.0	11.0	11.0	11.0
	Speed (RPM) @ 24v	17	30	45	60	90	144	300	360
	Speed (RPM) @ 12v	9	15	23	30	45	72	150	180

## Specific benefits

- High peak torque output
- Zero cogging
- Low inertia
- Rapid acceleration
- Stable up to high temperatures
- High instantaneous torque
- Long brush life
- Controllable with servo amplifiers
- Design options include custom shaft, encoders and pulleys

sales@printedmotorworks.com  
 +44 1420 594 140  
 Printed Motor Works Limited  
 Newman Lane, Alton  
 Hampshire GU34 2QW, UK



# GPG12 Series

We have two designs for the GPG series depending on the ratio you require.

Please see the table below for the various ratios and the corresponding design.

Design A	12:1, 40:1, 60:1, 80:1, 120:1, 206:1
Design B	10:1, 25:1

## Design A

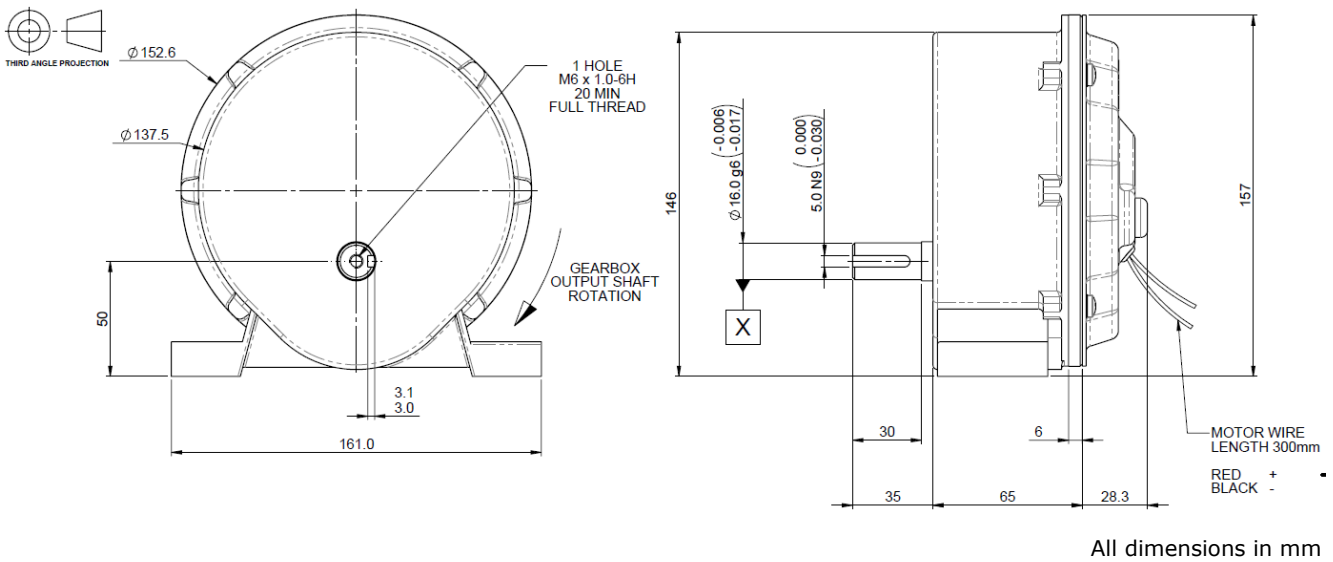

All dimensions in mm

## Design B

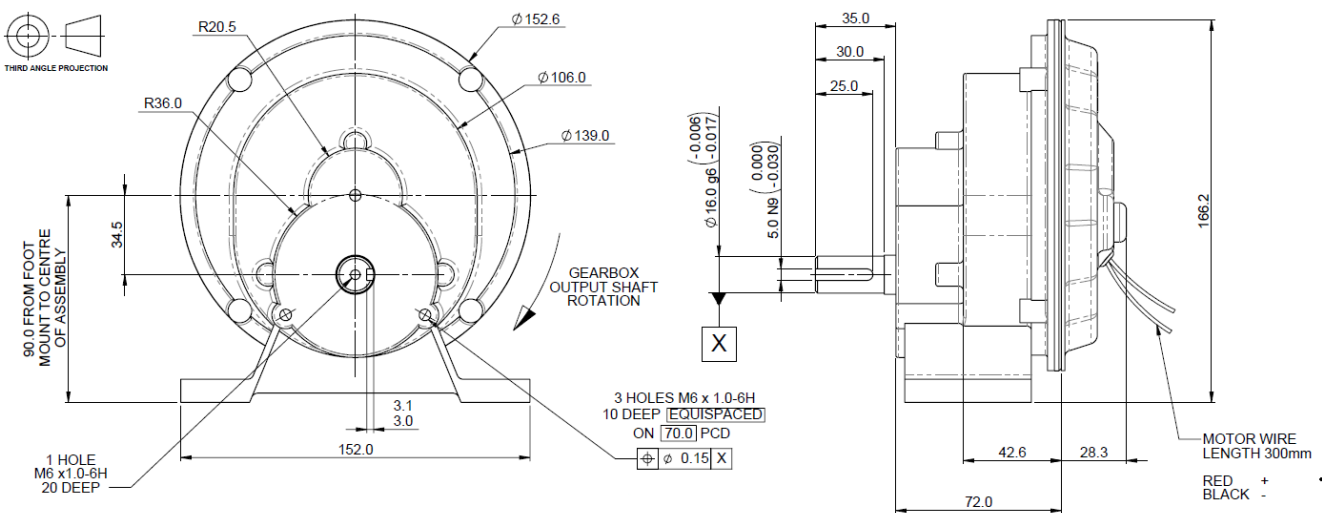

All dimensions in mm

# GPG12 Series

## Applications:

Biomedical analysis, inspection systems, X-Y tables, wheel drive, automatic door actuators, general automation, advertising screens, weld wire feed, seat elevation adjustment, turret drive.

## Markets:

Industrial automation, medical, life sciences, aerospace & defence, printing, logistics, instrumentation, test and measurement, oil & gas and offshore marine.

## Design Modifications

- Encoders
- Timing pulleys
- Tri-rated cable
- Customised shafts
- EMC suppression
- Connectors

## Standard Encoder Option:

Motor	Counts per Rev. CPR	Channels	Type	Supply Voltage V
GPGM12	500	A + B + Index	Optical	+ 5
GPGN12	500	A + B + Index	Optical	+ 5
GPGM12LR	500	A + B + Index	Optical	+ 5
GPGN12LR	500	A + B + Index	Optical	+ 5

## Suggested Drives:

### **PWM24/10** *Basic motor speed control* **PWM24/25**

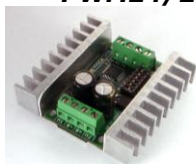

6-30Vdc for basic Speed control applications. 10Amp and 25Amp with single and twin axis control.

### **JUNUS** *General speed control applications*



20-180Vdc for Velocity and Torque control with 6 digital I/O. 5Amp - 30Amp variants, RS232 communication.

### **ACCELNET** *General servo applications*



20-180Vdc for Velocity, Torque and Position control with 11 digital I/O and Encoder feedback. 5Amp - 36Amp variants, RS232 & Macro communication.

# GPG12 Series

Ratio	Drive train details	Backlash(degrees)	Arc mins	Radial Load (Kg)
206:1	Steel Gear	0.24±0.05°	15.0	230
120:1	Steel Gear	0.49±0.05°	29.4	230
80:1	Steel Gear	0.11±0.05°	6.6	230
60:1	Steel Gear	0.91±0.05°	54.6	230
40:1	Steel Gear	0.45±0.05°	27.0	230
25:1	Steel Gear(Planetary)	0.46±0.05°	27.6	230
12:1	MC Nylon Gear	0.12±0.05°	7.2	230
10:1	MC Nylon Gear(Planetary)	0.46±0.05°	27.6	230

